

# **Bluetooth Class 1 OEM Module**

## **Parani-BCD110**

### **Product Datasheet**

Version 1.0.3  
February 1, 2017

Sena Technologies, Inc.

**Copyright**

Copyright 2002~2017, Sena Technologies, Inc. All rights reserved.

Sena Technologies reserves the right to make changes and improvements to its product without providing notice.

**Trademark**

Parani™ is a trademark of Sena Technologies, Inc.

Windows® is a registered trademark of Microsoft Corporation.

Bluetooth® is a registered trademark of Bluetooth SIG (Special Interest Group).

**Notice to Users**

When a system failure may cause serious consequences, protecting life and property against such consequences with a backup system or safety device is essential. The user agrees that protection against consequences resulting from system failure is the user's responsibility.

This device is not approved for life-support or medical systems.

Changes or modifications to this device not explicitly approved by Sena Technologies will void the user's authority to operate this device.

**Precautions and Safety**

Do not drop or subject the device to impact. Damage to your products may result from improper use.

Keep away from harsh environments including humid, dusty, and smoky areas. Damage to your products may result from improper use.

Do not use excessive force on the buttons or attempt to disassemble the device. Damage to your products may result from improper use.

Do not place heavy objects on the product. Damage to your products may result from improper use.

**Contact Information**

Technical support email: [support@senanetworks.com](mailto:support@senanetworks.com)

Company website: <http://www.senanetworks.com>

## Contents

1. General .....	4
1.1 Features .....	4
1.2 Applications .....	4
1.3 Device Diagram .....	5
1.4 Pin Diagram .....	5
1.5 Pin Descriptions .....	6
1.6 Dimensions and PCB land pattern .....	8
2. Electrical characteristics .....	11
2.1 Absolute maximum ratings .....	11
2.2 Recommended operating conditions .....	11
2.3 Power Consumptions .....	11
3. RF Characteristics .....	12
3.1 Basic Data Rate .....	12
3.1.1 Transmitter Performance .....	12
3.1.2 Receiver Performance .....	12
3.2 Enhanced Data Rate .....	13
3.2.1 Transmitter performance .....	13
3.2.2 Receiver performance .....	14
4. Device Terminal Descriptions .....	15
4.1 UART Interface .....	15
4.2 USB Interface .....	15
4.3 PCM CODEC Interface .....	16
4.4 Programmable bi-directional Input/Output port: PIO port .....	16
4.5 Reset Interface .....	17
5. Application Schematic .....	18
6. Software Stack .....	22
7. Solder Profiles .....	23
8. Packaging Information .....	24
9. Certificate Information .....	25
9.1 FCC .....	25
9.1.1 FCC Compliance Statement .....	25
9.1.2 RF Exposure Statement .....	25
9.1.3 Do not .....	25
9.2 CE .....	25
9.3 IC .....	26
9.4 KC .....	26
9.5 TELEC .....	26
9.6 SIG .....	26

## 1. General

The Parani-BCD110 is a Bluetooth Class 1 OEM module for OEM manufacturers who want to implement Bluetooth Class 1 functionality with their products cost effectively and also in timely manner. OEM manufactures can implement Bluetooth functionality to their products with low cost and in timely manner by using BCD110's firmware which supports the field-proven standard SPP (Serial Port Profile), Sena I/O (Input/Output) profile for bidirectional I/O port and SCO (synchronous Connection Oriented) connection for PCM interface.

The BCD110 supports Class 1 Bluetooth transmission level for longer communication distance typically ranges from 200 m up to 1 km. The BCD110 supports UART, USB, PCM, PIO interfaces for the communication with the OEM products.

The BCD110 is provided with the firmware which not only conforms to Bluetooth v2.0 but also supports SPP (Serial Port Profile), Sena I/O profile and SCO connection by default. The BCD110\_V3.0 firmware supports up to 7 simultaneous multiple connections and is designed to work out-of-box for real world SPP applications such as POS (Point-of-sales), industrial automation, remote metering and other various applications. Optionally, the BCD110 can be supplied with only software stack up to HCI level so entire Bluetooth stack runs on the host side for the application such as USB dongles for computers, or OEM manufacturers can even develop and embed their own firmware into the BCD110.

The BCD110 is fully qualified with Bluetooth v.2.0+EDR specification so OEM manufacturers can save cost and time for overall OEM product certifications, which makes the BCD110 ideal solution for larger volume and cost sensitive applications.

### 1.1 Features

- Bluetooth Class 1
- Bluetooth v2.0+EDR specification
- Transmit Power: +18dBm Typical
- Receive sensitivity: -90dBm (0.1% BER)
- Integrated 8Mbit Flash Memory
- Supports Serial Port Profile (SPP), Sena I/O Profile, SCO Connection
- Working distance (In an open field): Nom.200m, up to 1000m
- Supports built-in chip, stub and dipole antennas
- Standard HCI over UART or USB
- BCD110V3 firmware supporting up to 7 simultaneous multiple connections
- Firmware upgrade via windows-based software (ParaniUpdater)
- Easy to use Windows configuration tool available.
- ROHS compliant

### 1.2 Applications

- High-speed data transceiver systems for long distance communication
- PCs/Personal Digital Assistants (PDA)
- Bluetooth USB dongle
- Bluetooth serial dongle
- Bluetooth access points
- Industrial automation devices
- Remote metering devices
- POS (Point-of-sales) devices

### 1.3 Device Diagram

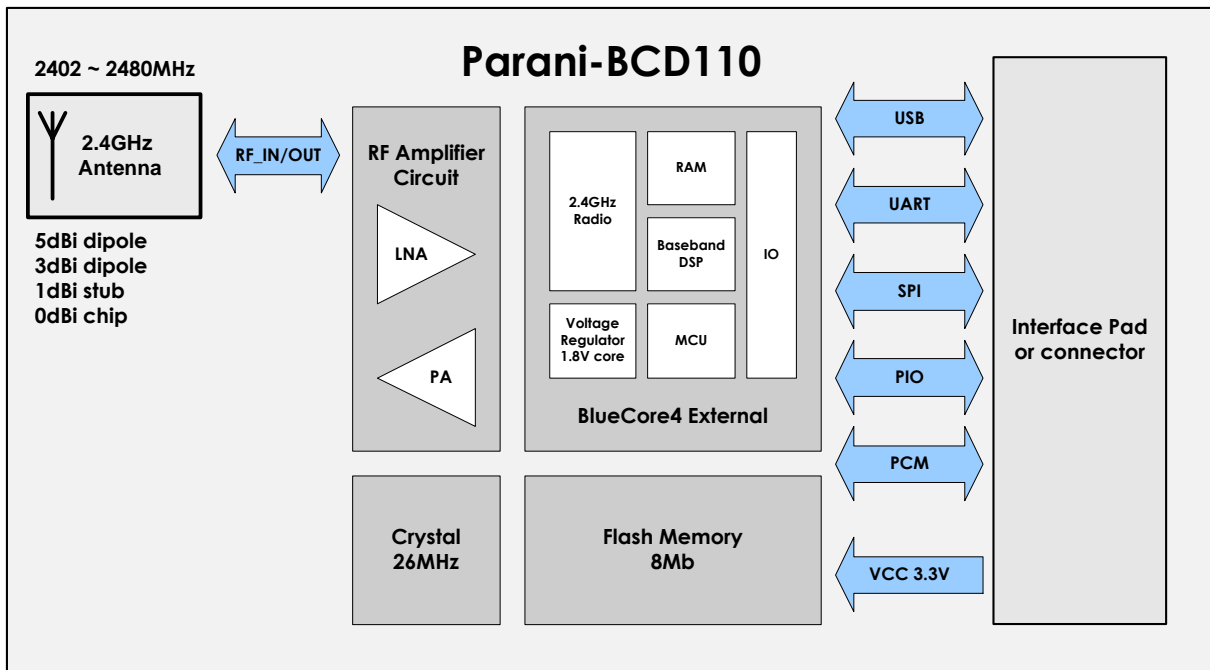

Figure 1-1 Device Diagram

### 1.4 Pin Diagram

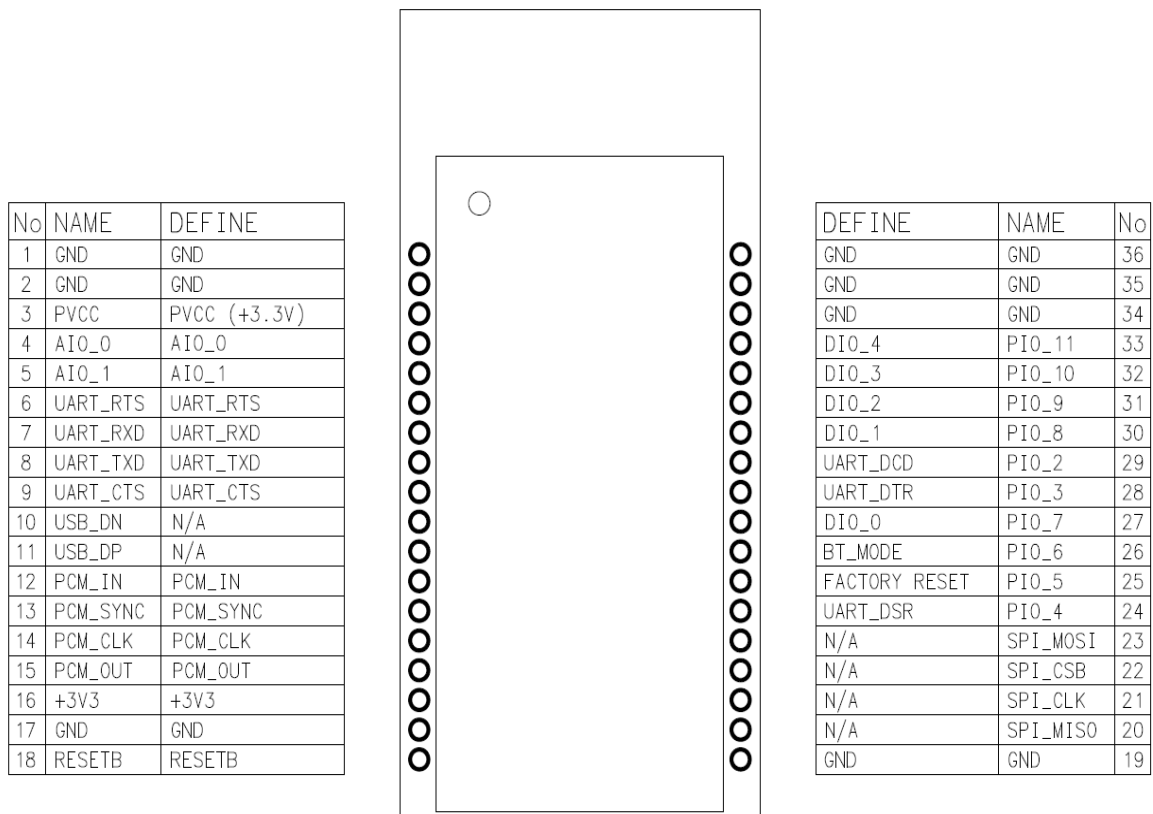

Figure 1-2 Pin diagram

## 1.5 Pin Descriptions

Function	Pin Name	Pin Number	Description
<b>USB Interface</b>	USB_DP	11	USB data plus
	USB_DN	10	USB data minus
<b>UART Interface</b>	UART_TXD	8	UART data output
	UART_RXD	7	UART data input
	UART_RTS	6	UART request to send active low
	UART_CTS	9	UART clear to send active low
<b>PCM Interface</b>	PCM_OUT	15	Synchronous data output
	PCM_IN	12	Synchronous data input
	PCM_SYNC	13	Synchronous data sync
	PCM_CLK	14	Synchronous data clock
<b>SPI Interface</b>	SPI_MISO	20	SPI data output
	SPI_MOSI	23	SPI data input
	SPI_CSB	22	Chip select for SPI, active low
	SPI_CLK	21	SPI clock
<b>PIO Interface</b>	PIO_2	29	Programmable input/output line
	PIO_3	28	Programmable input/output line
	PIO_4	24	Programmable input/output line
	PIO_5	25	Programmable input/output line
	PIO_6	26	Programmable input/output line
	PIO_7	27	Programmable input/output line
	PIO_8	30	Programmable input/output line
	PIO_9	31	Programmable input/output line
	PIO_10	32	Programmable input/output line
	PIO_11	33	Programmable input/output line
<b>AIO</b>	AIO_0	4	Analogue programmable input/output line
	AIO_1	5	Analogue programmable input/output line
<b>Power</b>	PVCC	3	Power supply for power amplifier, 3.3V
	+3V3	16	Power supply for system, 3.3V
	GND	1, 2, 17, 19 34, 35, 36	Ground
<b>Others</b>	RESETB	18	Reset, active low, > 5ms to cause a reset

Table 1-1 Pin descriptions

Function	Pin Name	STATE		
		Define (BCD110V3)	Direction	Pull-up/down
<b>USB</b>	USB_DP	-	Input	Weak pull-up
	USB_DN	-	Input	Weak pull-up
<b>UART</b>	UART_TXD	UART_TXD	Output	Tri-stated with weak pull-up
	UART_RXD	UART_RXD	Input	Weak pull-down
	UART_RTS	UART_RTS	Output	Tri-stated with weak pull-up
	UART_CTS	UART_CTS	Input	Weak pull-down
<b>PCM</b>	PCM_OUT	- PCM_OUT	Output	Tri-stated with weak pull-down
	PCM_IN	- PCM_IN	Input	Weak pull-down
	PCM_SYNC	- PCM_SYNC	Input	Weak pull-down
	PCM_CLK	- PCM_CLK	Input	Weak pull-down
<b>SPI</b>	SPI_MISO	-	Output	Tri-stated with weak pull-down
	SPI_MOSI	-	Input	Weak pull-down
	SPI_CSB	-	Input	Weak pull-up
	SPI_CLK	-	Input	Weak pull-down
<b>PIO</b>	PIO_2	UART_DCD	Output	Weak pull-up
	PIO_3	UART_DTR	Output	Weak pull-up
	PIO_4	UART_DSR	Input	Weak pull-down
	PIO_5	FACTORY_RESET	Input	Weak pull-up
	PIO_6	BT_MODE	Input	Weak pull-up
	PIO_7	DIO_1	Input/Output	-
	PIO_8	DIO_2	Input/Output	-
	PIO_9	DIO_3	Input/Output	-
	PIO_10	DIO_4	Input/Output	-
	PIO_11	DIO_5	Input/Output	-
<b>AIO</b>	AIO_0	AIO_0	Input	Driving low
	AIO_1	AIO_1	Input	Driving low
<b>Others</b>	RESETB	RESETB	Input	Weak pull-up

Table 1-2 Pin States on Reset (BCD110V3)

1.6 Dimensions and PCB land pattern

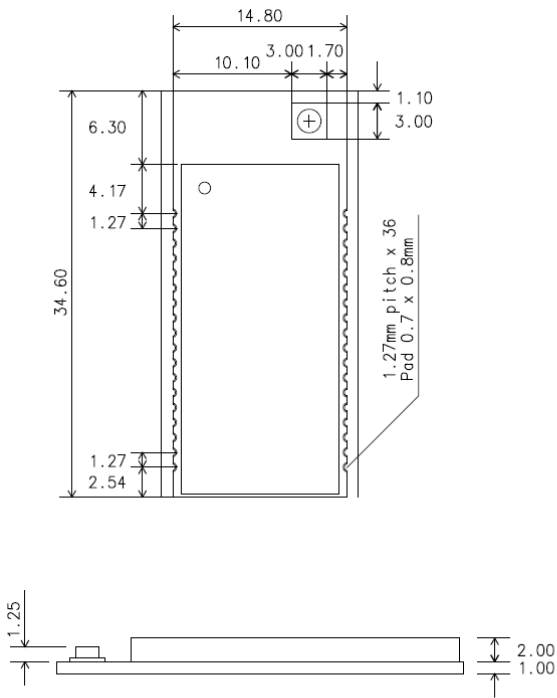

Figure 1-3 BCD110SU Dimensions

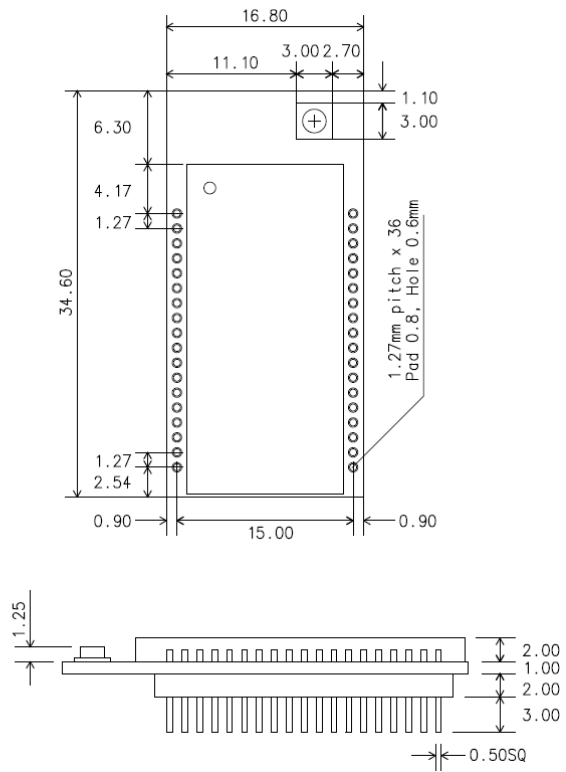

Figure 1-4 BCD110DU Dimensions

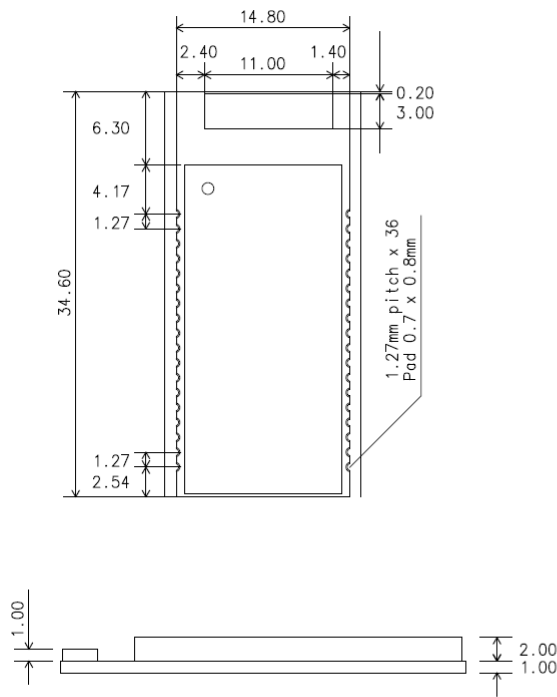

Figure 1-5 BCD110SC Dimensions

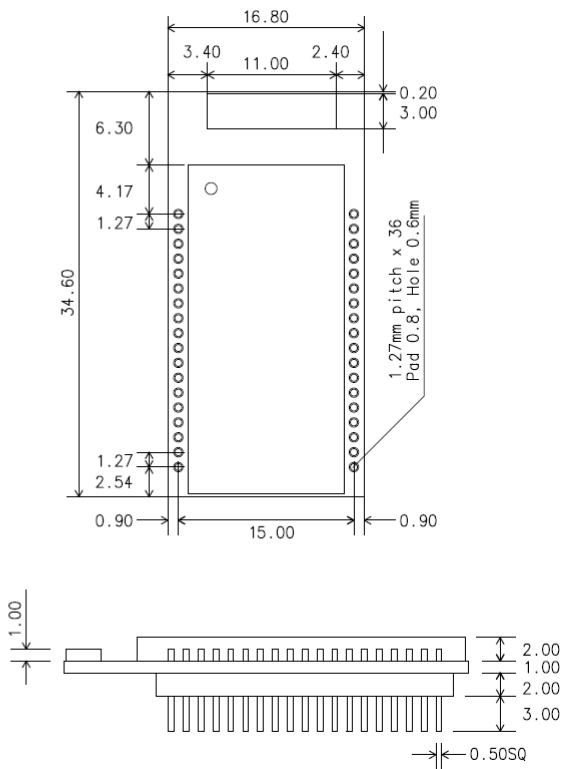

Figure 1-6 BCD110DC Dimensions



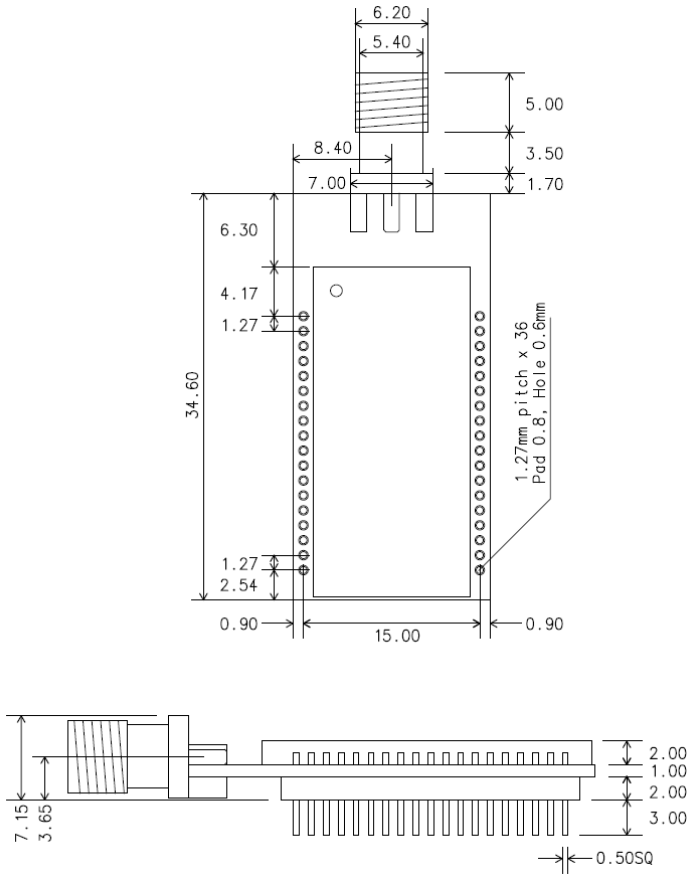

Figure 1-7 BCD110DS Dimensions

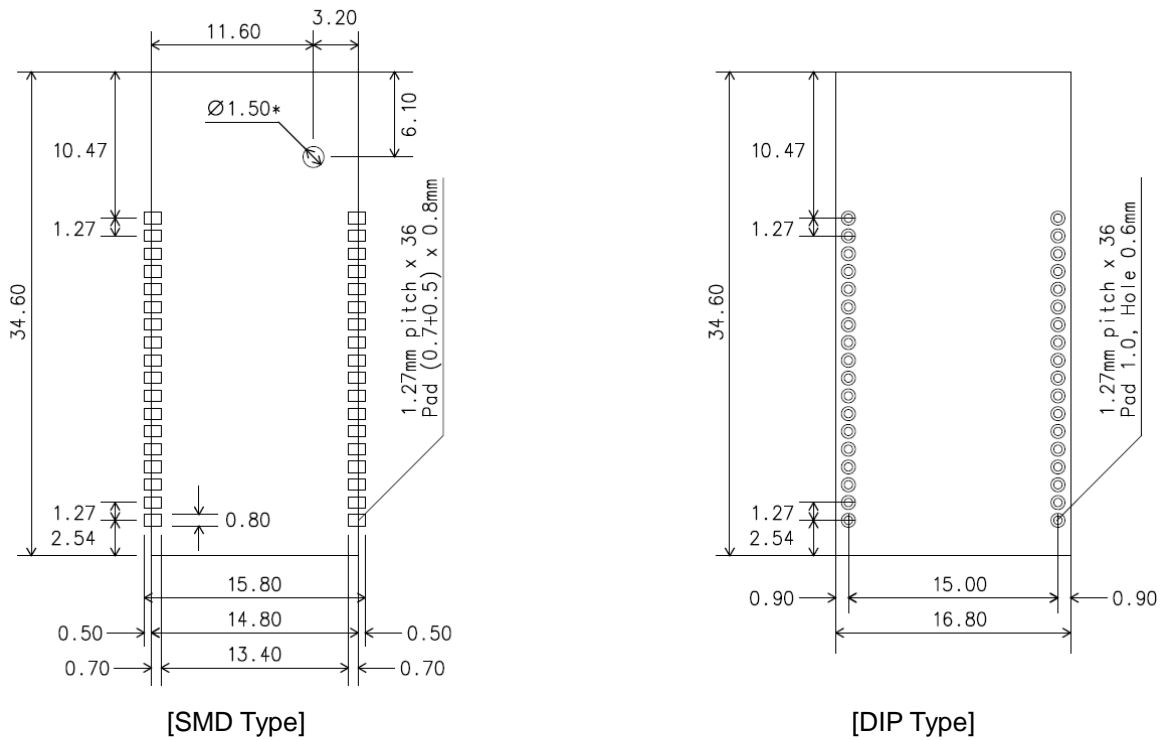

Figure 1-8 Recommended Land Pattern

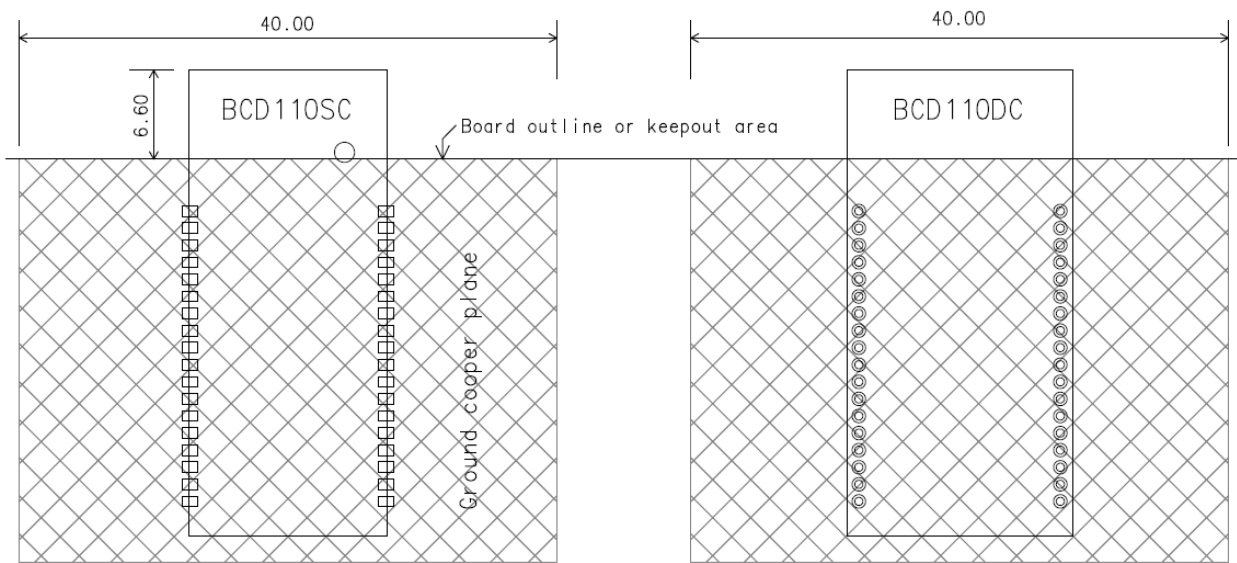

Figure 1-4 Recommended Board Layout

\*BCD110SU, DU, DS has no keep-out area.

## 2. Electrical characteristics

### 2.1 Absolute maximum ratings

Ratings		Min	Max	Unit
Storage Temperature		-40	+85	°C
Operating Temperature		-40	+85	°C
Supply voltage	PVCC	-0.4	3.6	V
	+3V3	-0.4	3.6	V
Other terminal voltages		GND – 0.4	+3V3 +0.4	V

Table 2-1 Absolute maximum ratings

### 2.2 Recommended operating conditions

Ratings		Min	Typ	Max	Unit
Operating Temperature		-40	25	+85	°C
Supply voltage	PVCC	2.7	3.3	3.6	V
	+3V3	2.7	3.3	3.6	V
	UART	3.0	3.3	3.6	V
	USB	3.1	3.3	3.6	V
Supply current	PVCC	100	150	200	mA
	+3V3	40	50	100	mA

Table 2-2 Recommended operating conditions

\* Total current consumption = operating mode: max 100mA, test mode: max. 200mA

### 2.3 Power Consumptions

Role	Operation Mode	UART Rate(kbps)	Current <sup>1)</sup>	Unit
-	Inquiry and page Scan	115.2	76	mA
-	Power on (Standby)	115.2	2	mA
	Connectable Mode(Mode3)	115.2	18	mA
	Connected (No data)	115.2-	15	mA
	Connected (file transfer)	115.2	75	mA
	Connected (file transfer)	9.6	74	mA

Table 2-3 Power consumptions (SPP)

<sup>1)</sup> Typical Average Current @3.3VDC, 25°C, Output Power=18dBm

### 3. RF Characteristics

#### 3.1 Basic Data Rate

##### 3.1.1 Transmitter Performance

RF Characteristics PVCC = 3.3V, 25°C		Min	Typ	Max	Bluetooth Specification	Unit
Output power		16	18	19	≤ 20	dBm
Power Density		16	18	19	≤ 20	dBm
Power Control		3	4	6	2 ≤ step ≤ 8	dB
TX Output Spectrum-Frequency range		2402	-	2480	2400 ~2483.5	MHz
TX Output Spectrum-20dB Bandwidth		-	900	-	≤ 1000	kHz
Adjacent Channel Power	F = F <sub>0</sub> ± 2MHz	-	-	-20	≤ -20	dBm
	F = F <sub>0</sub> ± 3MHz	-	-	-40	≤ -40	dBm
	F = F <sub>0</sub> ± > 3MHz	-	-	-40	≤ -40	dBm
Modulation Characteristics	Δf <sub>1avg</sub>	145	165	175	140 ≤ Δf <sub>1avg</sub> ≤ 175	kHz
	Δf <sub>2avg</sub>	115	155	-	Δf <sub>2avg</sub> ≥ 115	kHz
	Δf <sub>2avg</sub> /Δf <sub>1avg</sub>	0.8	0.95	-	(Δf <sub>1avg</sub> /Δf <sub>2avg</sub> ) ≥ 0.8	-
Initial Carrier Frequency Tolerance		-20	-	20	≤ ±75	kHz
Carrier Frequency Drift	Drift rate	-20	-	20	≤ ±20	kHz/50μs
	1 slot Freq Drift	-25	-	25	≤ ±25	kHz
	5 slot Freq Drift	-40	-	40	≤ ±40	kHz

Table 3-1 Transmitter performance at basic data rate

##### 3.1.2 Receiver Performance

RF Characteristics Temperature 25°C		Min	Typ	Max	Bluetooth Specification	Unit
Sensitivity - Single slot packets (0.1%)		-	-90	-70	≤ -70	dBm
Sensitivity - Multi slot packets (0.1%)		-	-90	-70	≤ -70	dBm
C/I performance at 0.1% BER	co-channel	-	-	-11	≤ -11	dB
	F = F <sub>0</sub> + 1MHz	-	-	0	≤ 0	kHz
	F = F <sub>0</sub> - 1MHz	-	-	0	≤ 0	dB
	F = F <sub>0</sub> + 2MHz	-	-	-20	≤ -20	dB
	F = F <sub>0</sub> - 2MHz	-	-	-30	≤ -30	dB
	F = F <sub>0</sub> - 3MHz	-	-	-40	≤ -40	dB
	F = F <sub>0</sub> + 5MHz	-	-	-40	≤ -40	dB
	F = F <sub>image</sub>	-	-	-9	≤ -9	dB

Blocking performance	0.030-2.000GHz	-10	-	-	$\geq -10$	dBm
	2.000-2.400GHz	-27	-	-	$\geq -27$	dBm
	2.500-3.000GHz	-27	-	-	$\geq -27$	dBm
	3.000-12.75GHz	-10	-	-	$\geq -10$	dBm
Inter-modulation performance		-39	-	-	$\geq -39$	dBm
Maximum input level at 0.1% BER		-20	0	-	$\geq -20$	dBm

Table 3-2 Receiver Performance at basic data rate

### 3.2 Enhanced Data Rate

#### 3.2.1 Transmitter performance

RF Characteristics PVCC = 3.3V, Temperature 25°C			Min	Typ	Max	Bluetooth Specification	Unit
Maximum RF Transmit Power			-2	2	-	-6 to +4	dB
Relative Transmit Power			-4	-	1	-4 to +1	dB
Carrier Frequency Stability	$\pi/4$ DQPSK	$ \omega_0 $	-10	-	10	$\leq \pm 10$ for all blocks	kHz
		$ \omega_i $	-75	-	75	$\leq \pm 75$ for all packets	kHz
		$ \omega_0 + \omega_i $	-75	-	75	$\leq \pm 75$ for all blocks	kHz
	8DPSK	$ \omega_0 $	-10	-	10	$\leq \pm 10$ for all blocks	kHz
		$ \omega_i $	-75	-	75	$\leq \pm 75$ for all packets	kHz
		$ \omega_0 + \omega_i $	-75	-	75	$\leq \pm 75$ for all blocks	kHz
Modulation Accuracy	$\pi/4$ DQPSK	RMS DEVM	-	-	20	$\leq 20$	%
		99% DEVM	-	-	30	$\leq 30$	%
		Peak DEVM	-	-	35	$\leq 35$	%
	8DPSK	RMS DEVM	-	-	13	$\leq 13$	%
		99% DEVM	-	-	20	$\leq 20$	%
		Peak DEVM	-	-	25	$\leq 25$	%
EDR Differential Phase Encoding			99	-	-	$\geq 99$	%
In-band Spurious Emissions (8DPSK)	$F \geq F_0 + 3\text{MHz}$		-	-	-40	$\geq -40$	dBm
	$F < F_0 + 3\text{MHz}$		-	-	-40	$\geq -40$	dBm
	$F = F_0 - 3\text{MHz}$		-	-	-40	$\geq -40$	dBm
	$F = F_0 - 2\text{MHz}$		-	-	-20	$\geq -20$	dBm
	$F = F_0 - 1\text{MHz}$		-	-	-26	$\geq -26$	dB
	$F = F_0 + 1\text{MHz}$		-	-	-26	$\geq -26$	dB
	$F = F_0 + 2\text{MHz}$		-	-	-20	$\geq -20$	dBm
	$F = F_0 + 3\text{MHz}$		-	-	-40	$\geq -40$	dBm

Table 3-3 Transmitter performance at enhanced data rate

3.2.2 Receiver performance

RF Characteristics Temperature 25°C		Min	Typ	Max	Bluetooth Specification	Unit	
Sensitivity at 0.01% BER	$\pi/4$ DQPSK	-	-88	-70	$\leq -70$	dBm	
	8DPSK	-	-85	-70	$\leq -70$	dBm	
BER floor performance		-	-	-60	$\leq -60$	dBm	
C/I Performance (co-channel at 0.1% BER)	$\pi/4$ DQPSK	-	-	13	$\leq +13$	dB	
	8DPSK	-	-	21	$\leq +21$	dB	
C/I Performance (Adjacent Channel Selectivity)	$F = F_0 + 1\text{MHz}$	$\pi/4$ DQPSK	-	-	0	$\leq 0$	dB
		8DPSK	-	-	5	$\leq +5$	dB
	$F = F_0 - 1\text{MHz}$	$\pi/4$ DQPSK	-	-	0	$\leq 0$	dB
		8DPSK	-	-	5	$\leq +5$	dB
	$F = F_0 + 2\text{MHz}$	$\pi/4$ DQPSK	-	-	-30	$\leq -30$	dB
		8DPSK	-	-	-25	$\leq -25$	dB
	$F = F_0 - 2\text{MHz}$	$\pi/4$ DQPSK	-	-	-20	$\leq -20$	dB
		8DPSK	-	-	-13	$\leq -13$	dB
	$F \geq F_0 + 3\text{MHz}$	$\pi/4$ DQPSK	-	-	-40	$\leq -40$	dB
		8DPSK	-	-	-33	$\leq -33$	dB
	$F \leq F_0 - 5\text{MHz}$	$\pi/4$ DQPSK	-	-	-40	$\leq -40$	dB
		8DPSK	-	-	-33	$\leq -33$	dB
	$F = F_{\text{Image}}$	$\pi/4$ DQPSK	-	-	-7	$\leq -7$	dB
		8DPSK	-	-	0	$\leq 0$	dB
	Maximum input level at 0.1% BER	$\pi/4$ DQPSK	-20	-	-	$\geq -20$	dBm
		8DPSK	-20	-	-	$\geq -20$	dBm

Table 3-4 Receiver performance at enhanced data rate

## 4. Device Terminal Descriptions

### 4.1 UART Interface

UART (Universal Asynchronous Receiver and Transmitter) interface provides a simple mechanism for communicating with other serial device using the RS232 protocol. When BCD110 is connected to another digital device, UART\_RX and UART\_TX transfer data between the two devices. The remaining two signals, UART\_CTS, UART\_RTS, can be used to implement RS232 hardware flow control where both are active low indicators. All UART connections are implemented using CMOS technology and have signaling levels of 0V and 3.3V

Parameter		Possible Values
Baud Rate	Minimum	1200 baud (2%Error)
	Maximum	3M baud (1%Error)
Flow Control		RTS/CTS or None
Parity		None, Odd or Even
Number of Stop Bits		1 or 2
Bits per Channel		8

Table 4-1 Possible UART Settings

### 4.2 USB Interface

BCD110 USB devices contain a full speed (12Mbps/s) USB interface that is capable of driving of a USB cable directly. No external USB transceiver is required. The device operates as a USB peripheral, responding to requests from a master host controller such as a PC. Both the OHCI and the UHCI standards are supported. The set of USB endpoints implemented behave as specified in the USB section of the Bluetooth specification v2.0+EDR or alternatively can appear as a set of endpoints appropriate to USB audio devices such as speakers. As USB is a Master/Slave oriented system (in common with other USB peripherals), BCD110 only supports USB slave operation.

The USB data lines emerge as pins USB\_DP and USB\_DN. These terminals are connected to the internal USB I/O buffers of the BCD110, therefore, have low output impedance. To match the connection to the characteristic of the USB cable, resistors must be placed in series with USB\_DP/USB\_DN and the cable. BCD110 features an internal USB pull-up resistor. This pulls the USB\_DP pin weakly high when BCD110 is ready to enumerate. It signals to the PC that it is a full speed (12Mbit/s) USB device.

The USB internal pull-up is implemented as a current source, and is compliant with section 7.1.5 of the USB specification v1.2. The internal pull-up pulls USB\_DP high to at least 2.8V when loaded with a 15KΩ±5% pull-down resistor (in the hub/host) when VDD\_PADS=3.1V. This presents a Thevenin resistance to the host of at least 900Ω.

### 4.3 PCM CODEC Interface

PCM (*Pulse Code Modulation*) is a standard method used to digitize audio (particularly voice) for transmission over digital communication channels. Through PCM interface in hardware and SCO connection in software, BCD110 supports continual transmission and reception of PCM data. [Thus, BCD110 reduces processor overhead for wireless headset applications] BCD110 offers a bi-directional digital audio interface that route directly into the baseband layer of the on-chip firmware. It does not pass through the HCI protocol layer.

Hardware on BCD110 allows the data to be sent to and received from a SCO connection.

Though Up to three SCO connections can be supported by the PCM interface at any one time, BCD110V3 firmware allows just one SCO connection.

BCD110 can operate as PCM interface Master generating an output clock of 128, 256, or 512kHz. When configured as PCM interface slave, it can operate with an input clock up to 2048kHz. BCD110 is compatible with a variety of clock formats, including Long Frame Sync, Short Frame Sync and GCI timing environments.

BCD110 interfaces directly to PCM audio devices including the following:

- Qualcomm MSM 3000 series and MSM 5000 series CDMA baseband devices
- OKI MSM7705 four channel A-law and u-law CODEC
- Motorola MC145481 8-bit A-law and u-law CODEC
- Motorola MC145483 13-bit linear CODEC
- STW 5093 and 5094 14-bit linear CODECs
- BCD110 is also compatible with the Motorola SSI™ interface

### 4.4 Programmable bi-directional Input/Output port: PIO port

PIO lines can be configured through software to have either weak or strong pull-downs. All PIO lines are configured as inputs with weak pull-downs at reset.

Any of the PIO lines can be configured as interrupt request lines or as wake-up lines from sleep modes. PIO\_6 or PIO\_2 can be configured as a request line for an external clock source. This is useful when the clock to BCD110 is provided from a system ASIC (*Application Specific Integrated Circuit*). Using PSKEY\_CLOCK\_REQUEST\_ENABLE (0x246), this terminal can be configured to be low when BCD110 is in Deep Sleep and high when a clock is required. The clock must be supplied within 4ms of the rising edge of PIO\_6 or PIO\_2 to avoid losing timing accuracy in certain Bluetooth operating modes.

BCD110 has two general purpose analogue interface pins, AIO\_0 and AIO\_1.

Analogue interface pins may be configured by BCD110\_V3.0 firmware.



## 4.5 Reset Interface

BCD110 may be reset from several sources: RESETB pin, power on reset, a UART break character or via a software configured watchdog timer.

The RESETB pin is an active low reset and is internally filtered using the internal low frequency clock oscillator. A reset will be performed between 1.5 and 4.0ms following RESETB being active. It is recommended that RESETB be applied for a period greater than 5ms.

The power on reset occurs when the VDD\_CORE supply falls below typically 1.5V and is released when VDD\_CORE rises above typically 1.6V.

At reset the digital I/O pins are set to inputs for bi-directional pins and outputs are tri-state. The PIOs have weak pull-downs.

### 5. Application Schematic

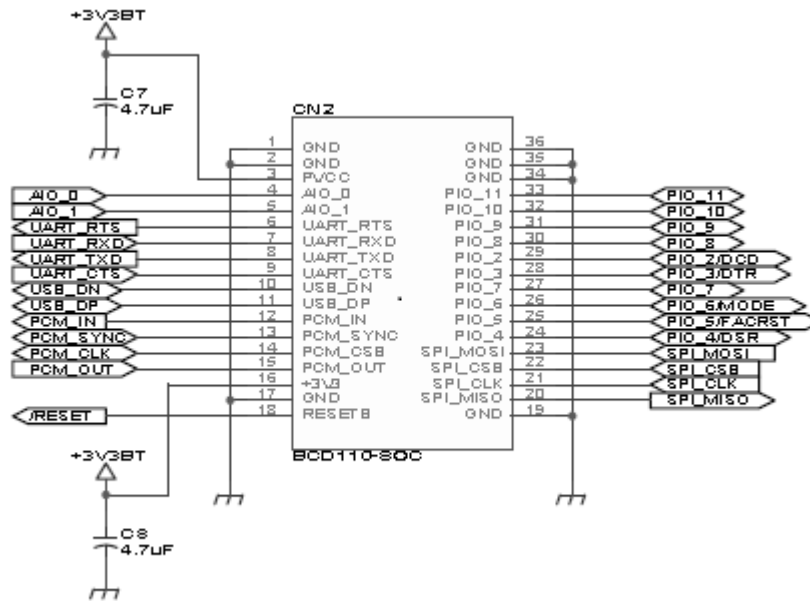

Figure 5-1 BT Module Interface

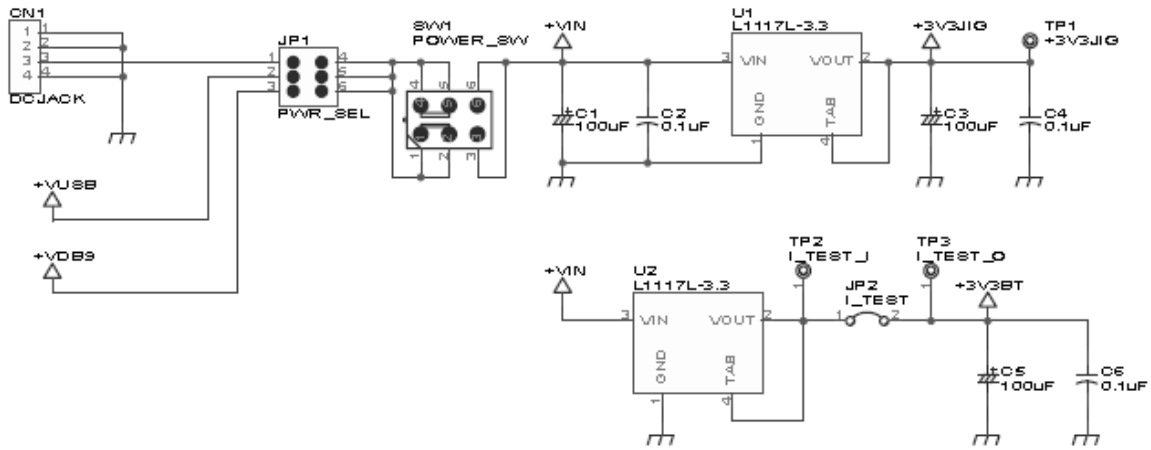

Figure 5-2 Power Supply and Reset Interface

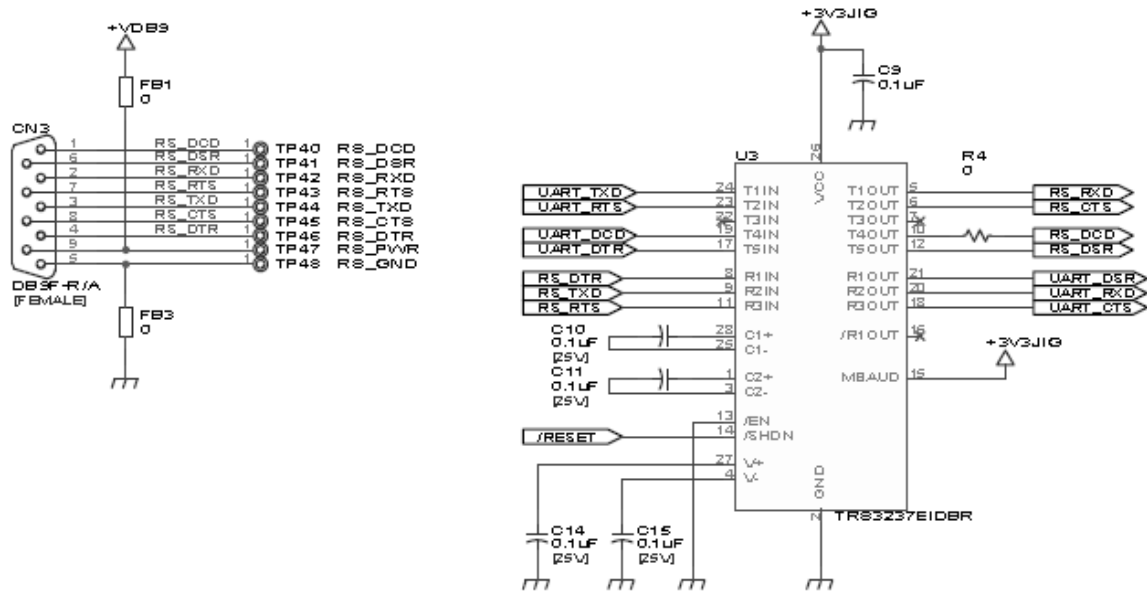
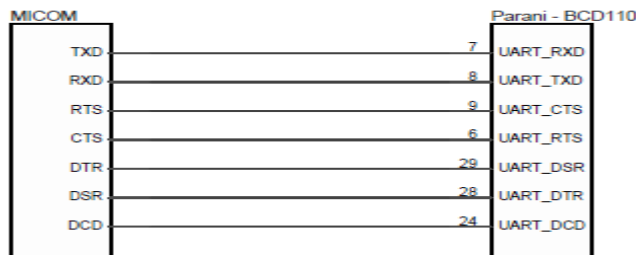

Figure 5-3 RS232 Serial Interface

[ When TTL level of MICOM is 3.3V ]



[ When TTL level of MICOM is 5.0V ]

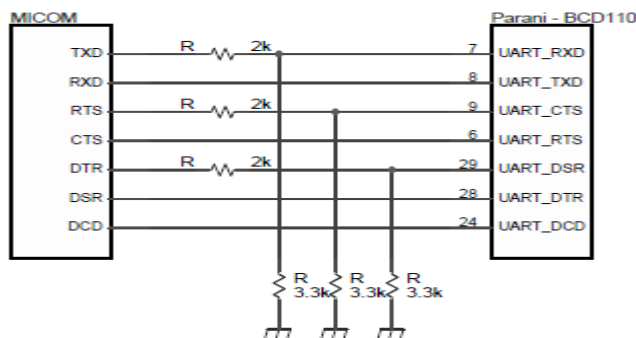

Figure 5-4 MICOM UART Interface

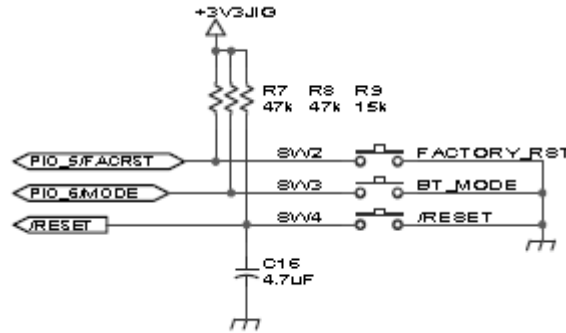

Figure 5-5 Switch Interface

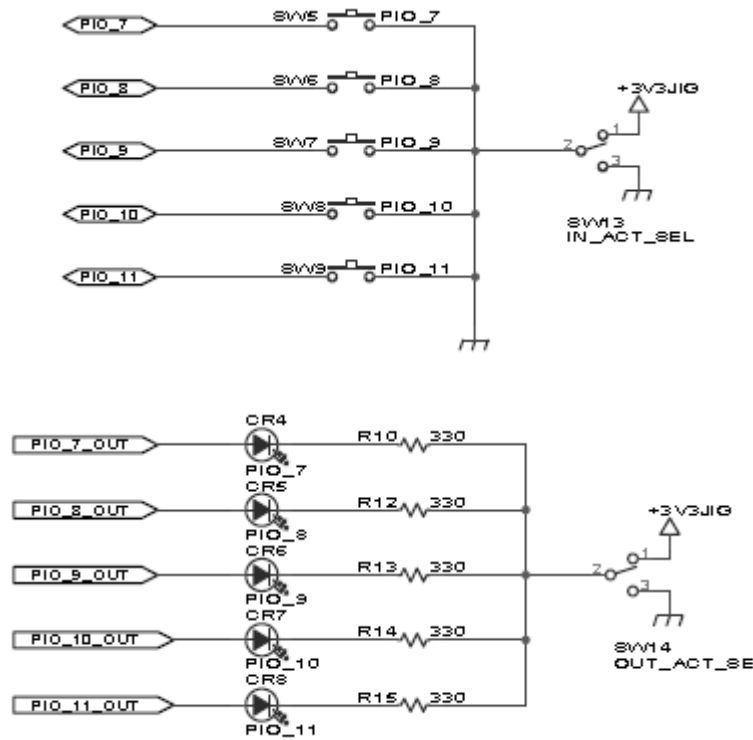

Figure 5-6 GPIO Interface

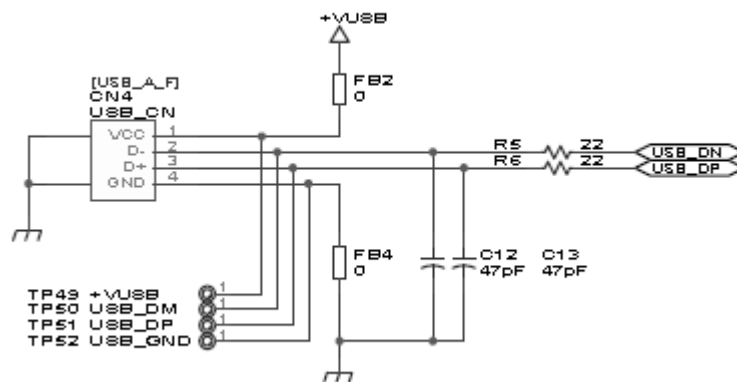

Figure 5-7 USB Interface

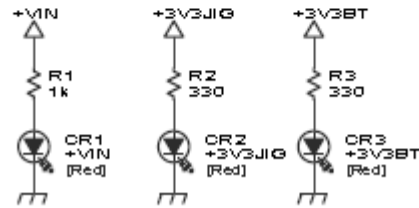
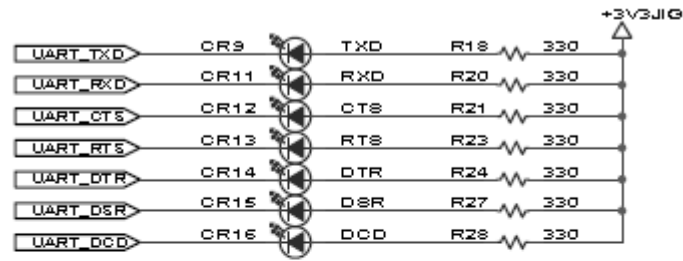

Figure 5-8 LED Interface

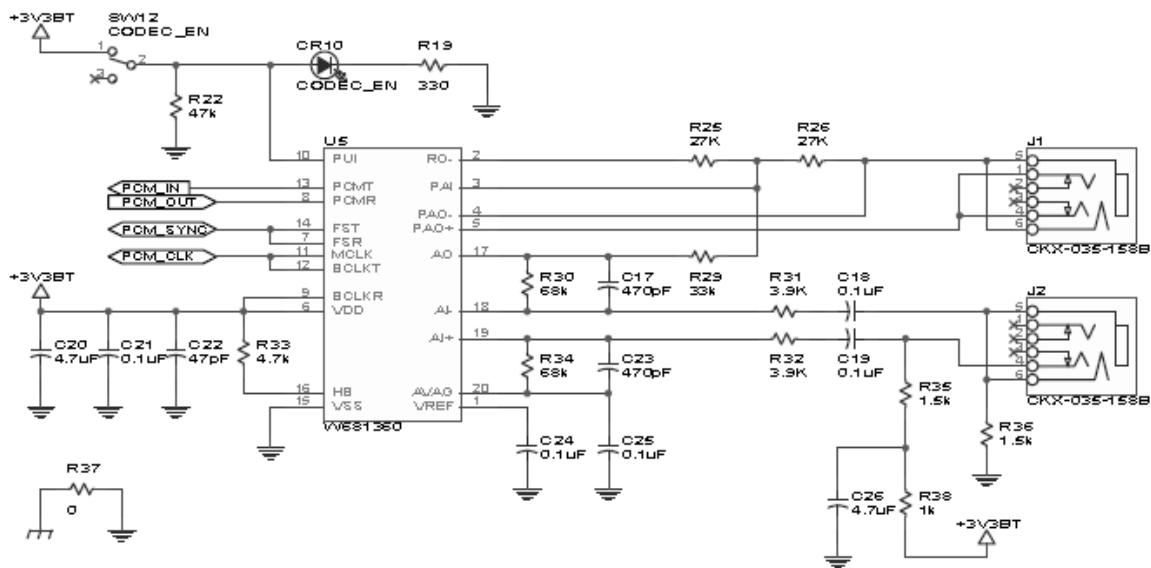

Figure 5-9 PCM Interface

## 6. Software Stack

The BCD110 is provided with the BCD110\_V3.0 firmware which not only conforms to Bluetooth v2.0 but also supports SPP (Serial Port Profile), Sena I/O profile and SCO connection by default. The firmware is designed to work out-of-box for real world SPP applications such as POS (Point-of-sales), industrial automation, remote metering and other various applications.

The BCD110\_V3.0 firmware can be configured and controlled by typical AT commands. Users can easily configure BCD110 by using a terminal program such as HyperTerminal and can use Bluetooth wireless communication without modifying user's existing serial communication program. In addition to the basic AT commands, BCD110 provides some expanded AT commands for various functions. User friendly ParaniWIN are also provided for easy setup on Microsoft Windows. To run AT commands on the BCD110, the BCD110 should be connected to the serial port of the user's own board or equivalent to carry the BCD110.

To shorten the overall development cycle or for quick verification during or before own development work, users might want to try BCD110\_V3.0 starter kits first for convenience. Also, please refer to the BCD110\_V3.0 user's manual for overall concept, configuration and complete AT commands list of the BCD110\_V3.0 firmware. The BCD110\_V3.0 user's manual can be downloaded from Sena support home page at <http://www.senanetworks.com/support/downloads/>.

Optionally, the BCD110 can be supplied with only software stack up to HCI level so users can develop and embed their own firmware version into the BCD110 or entire Bluetooth stack runs on the host side for the application such as USB dongle for computers. Regarding these custom firmware options, please contact a Sena representative for more detail.

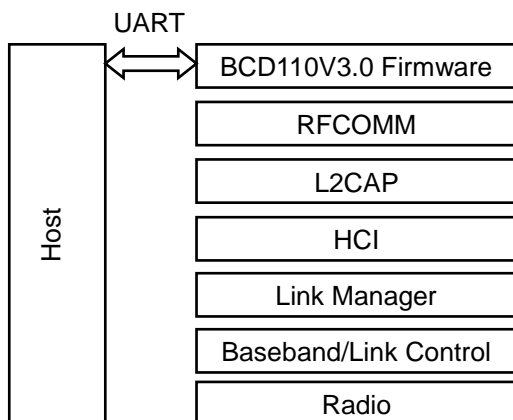
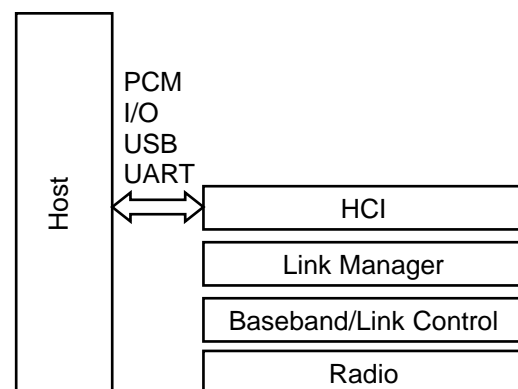

Figure 6-1 BCD110\_V3.0 Firmware Bluetooth software stack



6-2 HCI firmware Bluetooth Software Stack

## 7. Solder Profiles

The soldering profile depends on various parameters necessitating a set up for each application. The data here is given only for guidance on solder re-flow. There are four zones:

- **Preheat Zone** – This zone raises the temperature at a controlled rate, typically 1-2.5°C /s
- **Equilibrium Zone** – This zone brings the board to a uniform temperature and also activates the flux. The duration in this zone (typically 2-3 minutes) will need to be adjusted to optimize the out gassing of the flux.
- **Reflow Zone** – The peak temperature should be high enough to achieve good wetting but not so high as to cause component discoloration or damage. Excessive soldering time can lead to intermetallic growth which can result in a brittle joint.
- **Cooling Zone** – The cooling rate should be fast, to keep the solder grains small which will give a longer lasting joint. Typical rates will be 2-5°C/s

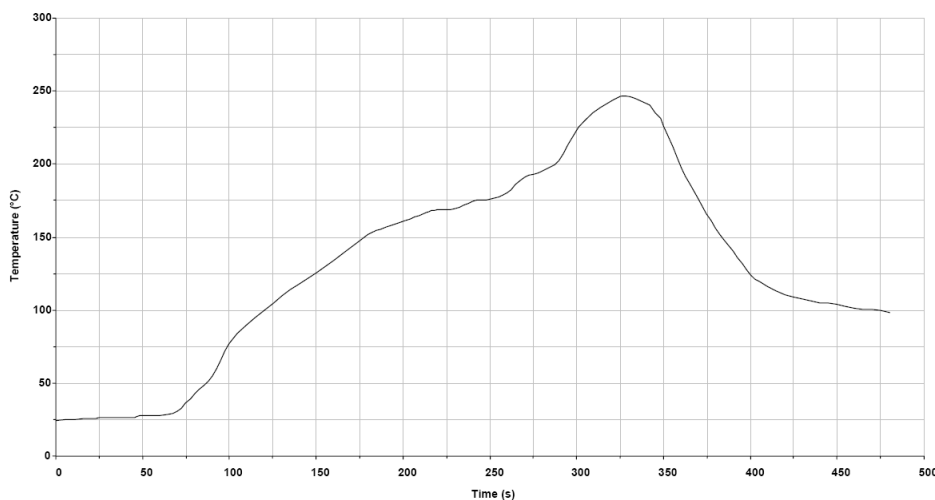

Figure 7-1 Typical Lead-Free Re-flow Solder Profile

Key features of the profile:

- Initial Ramp = 1-2.5°C/sec to 175°C±25°C equilibrium
- Equilibrium time = 60 to 180 seconds
- Ramp to Maximum temperature (245°C) = 3°C/sec max.
- Time above liquids temperature (217°C): 45~90 seconds
- Device absolute maximum reflow temperature: 260°C

The BCD110 will withstand the specified profile up to two reflows to a maximum temperature of 260°C

8. Packaging Information

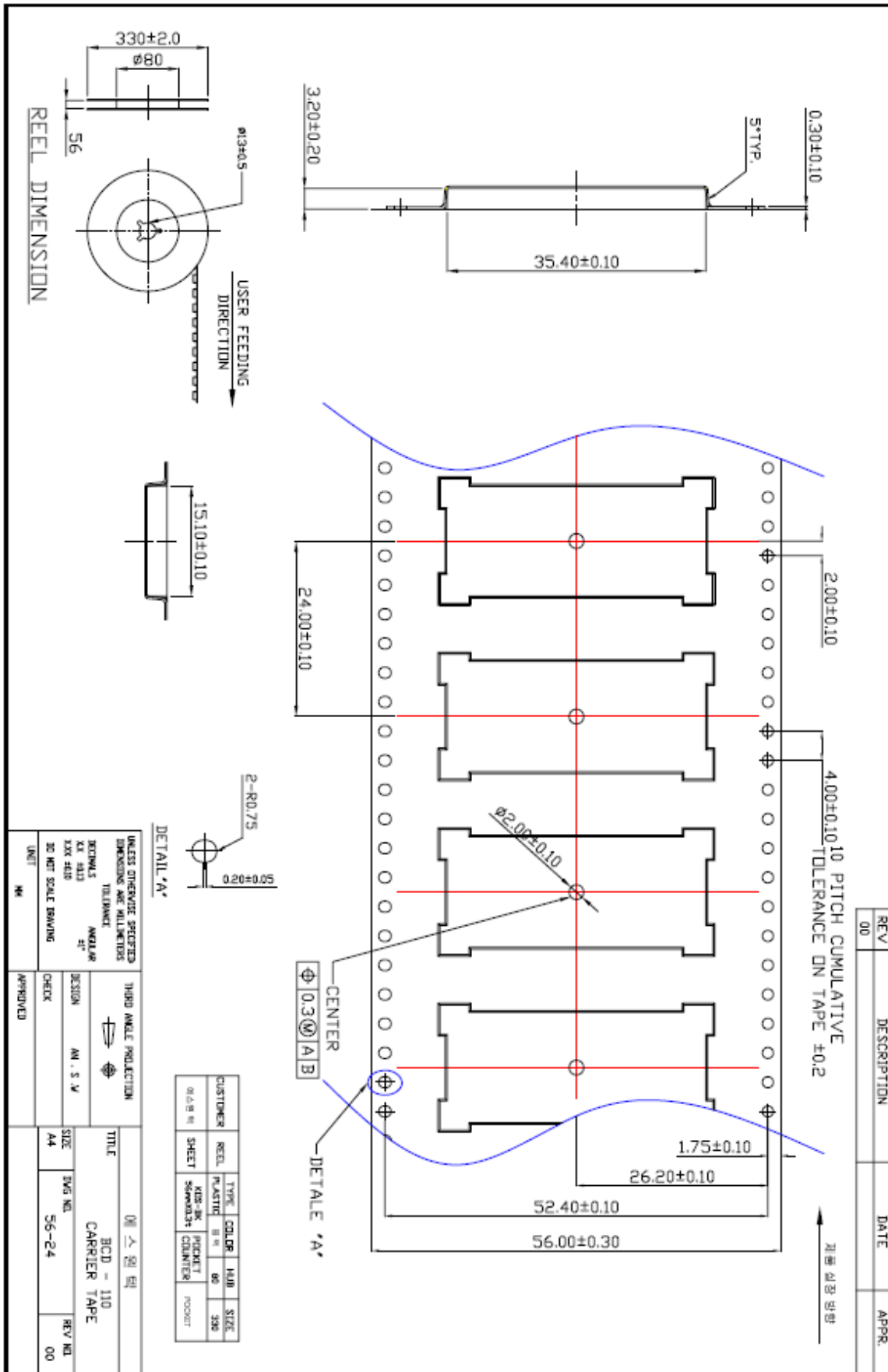

Figure 8-1 Tape & Reel Information



## 9. Certificate Information

### 9.1 FCC

FCC Rule: Part 15 Subpart C Section 15.247

FCCID: S7A-IW05

#### 9.1.1 FCC Compliance Statement

This device complies with part 15 of the FCC Rules. Operation is subject to the following two conditions:

- (1) This device may not cause harmful interference, and
- (2) This device must accept any interference received,

Including interference that may cause undesired operation

#### Information to User

This equipment has been tested and found to comply with limits for a Class B digital device, Pursuant to Part 15 of the FCC Rules. These limits are designed to provide reasonable protection against harmful interference in a residential installation.

This equipment generate, uses and can radiate radio frequency energy and, if not installed and used in accordance with the instructions, may cause harmful interference to radio communications.

However, there is no guarantee that interference will not occur in a particular installation. If this equipment does cause harmful interference to radio or television reception, which can be determined by turning the equipment off and on, the user is encouraged to try to correct the interference by on or more of the following measures:

- Reorient or relocate the receiving antenna.
- Increase the separation between the equipment and receiver-Connect the equipment into an outlet a circuit different form that to which the receiver is connected.
- Consult the dealer or an experienced radio/TV technician for help.

#### 9.1.2 RF Exposure Statement

The equipment complies with FCC RF radiation exposure limits set forth for an uncontrolled environment. This device and its antenna must not be co-located or operation in conjunction with any other antenna or transmitter.

#### 9.1.3 Do not

Any changes or modifications to the equipment not expressly approved by the party responsible for compliance could void user's authority to operate the equipment.

## 9.2 CE



Declare under our own responsibility that the product

Bluetooth Module

Brand name: SENNA

Model No.: IW05

To which this declaration refers conforms with the relevant standards or other standardizing documents

EN 60950-1

ETSI EN 301 489-1

ETSI EN 301 489-17

ETSI EN 300 328

According to the regulations in Directive 1999/5/EC

**9.3 IC**

Radio Cert. No.: IC: 8154A-IW05

**9.4 KC**

Type Registration  
Certification No: MSIP-CRM-SNA-IW05

**9.5 TELEC**

Technical Regulations for Specified Radio Equipment Article 2, Section 1 (19)  
Certification No:  
Parani-BCD110 : 011-160054

**9.6 SIG****QDID: B016862**

Model Name: Parani-BCD110

Core Version: 2.0+EDR

Product Type: End Product

Declared Specifications: Baseband Conformance, Radio, Service Discovery Protocol,  
Logical Link Control and Adaption Protocol, Generic Access Profile, Link Manager, RFCOMM,  
Serial Port Profile, Host Controller Interface, Summary ICS, Product Type